

# Celsus UK - Stalk Control Instructions

ASC2623

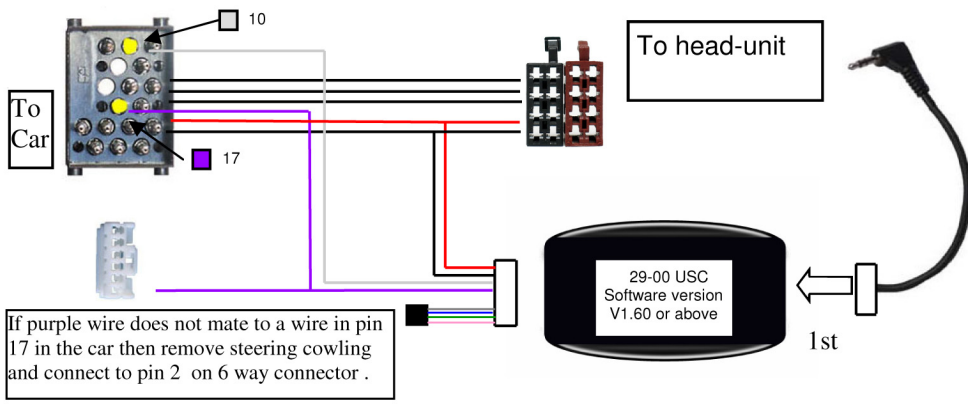

**1-ALWAYS CONNECT THE HEAD-UNIT CABLE ADAPTER 1st before ignition is turned on!**

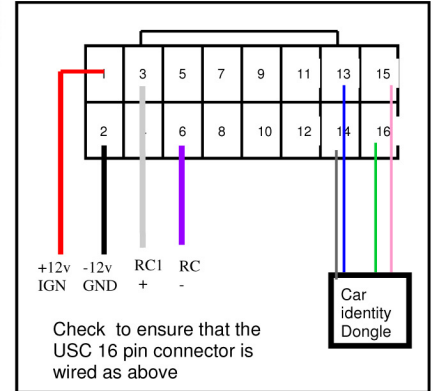

1. Turn off the ignition supply to the car!
2. Remove the OEM head-unit and identify the audio connector and ensure it mates correctly with the connector supplied with the cable.
3. Connect the cable to the car and to the ISO connectors on the new radio.
4. Check that the red wire is a 12V IGNITION source in the car then turn on ignition
5. Test unit before fully fitting radio and trims back.
6. If unit does not work, connect purple wire beneath steering column as shown.

**If Problems:** Check that correct adapter has been used and links are in the correct place. Always disconnect from the power supply if you change the head-unit adapter lead. Check that Red wire is 12V ignition and not Permanent power. Check that head-unit is earthed and black wire is earth. Check all connections are the same as the wiring diagram shown here. If using PS-PCB software version (written on control box) must be 1.95 or higher. If not ASCPIO3V must be used.

# Celsus UK - Stalk Control Instructions

ASC2623

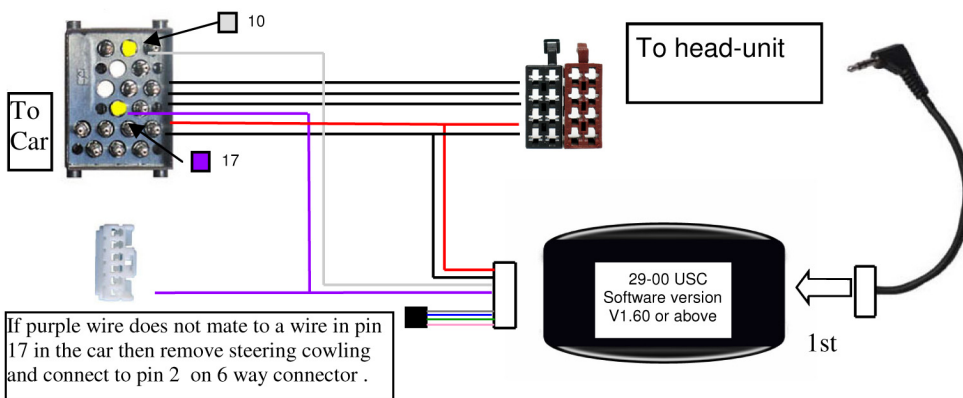

**1-ALWAYS CONNECT THE HEAD-UNIT CABLE ADAPTER 1st before ignition is turned on!**

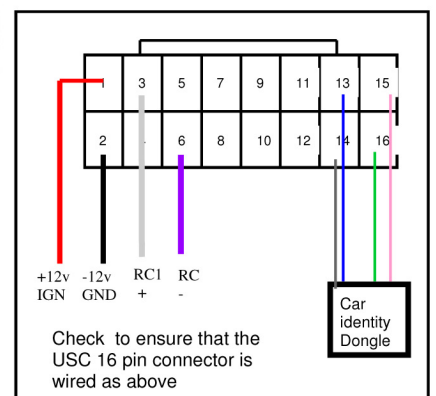

1. Turn off the ignition supply to the car!
2. Remove the OEM head-unit and identify the audio connector and ensure it mates correctly with the connector supplied with the cable.
3. Connect the cable to the car and to the ISO connectors on the new radio.
4. Check that the red wire is a 12V IGNITION source in the car then turn on ignition
5. Test unit before fully fitting radio and trims back.
6. If unit does not work, connect purple wire beneath steering column as shown.

**If Problems:** Check that correct adapter has been used and links are in the correct place. Always disconnect from the power supply if you change the head-unit adapter lead. Check that Red wire is 12V ignition and not Permanent power. Check that head-unit is earthed and black wire is earth. Check all connections are the same as the wiring diagram shown here. If using PS-PCB software version (written on control box) must be 1.95 or higher. If not ASCPIO3V must be used.